

Series Resistance Compensation

1. Patch clamping

• Patch clamping is a form of voltage clamping, a technique that uses a feedback circuit to set the membrane potential (V_m) of a cell to a desired command value (V_{com}). With membrane potential fixed, the membrane current is measured. The patch clamp amplifier thus must function as a current-to-voltage converter to allow this current to be displayed on an oscilloscope or computer.

A. The patch clamp amplifier is a differential amplifier that operates to make the output equal to the difference between the two inputs.

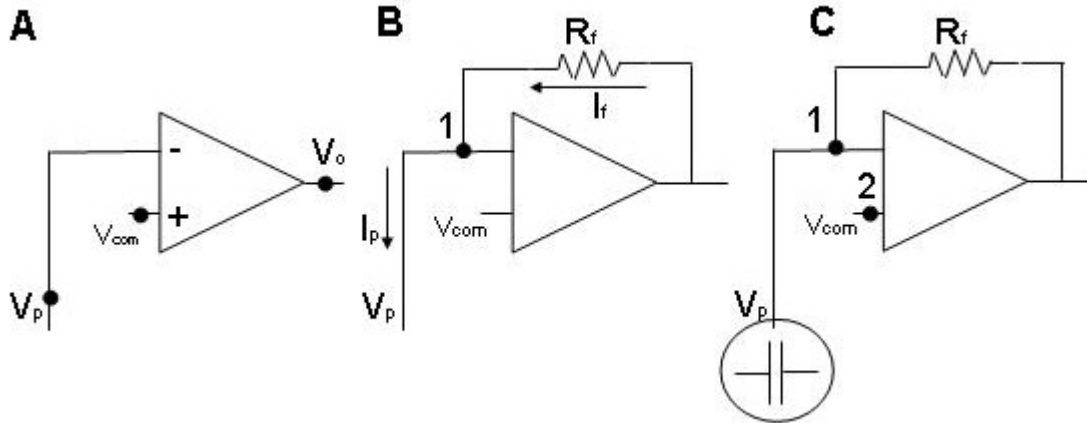

$$V_o = V_{com} - V_p.$$

B. When a feedback resistor, R_f , is placed between the output and the negative input of the amplifier (point 1) a current flows through the feedback resistor to make the voltage at 1 (i.e. V_p) equal to that at V_{com} . V_{com} becomes the “command” for voltage clamping the pipette voltage, V_p . Ohm’s Law states that a current will flow through this resistance proportional to the voltage difference between the two ends of the resistor.

$$I_f = (V_o - V_p) / R_f$$

Rearranging this equation gives:

$$V_o = I_f R_f + V_p$$

Since current must be conserved, the current flowing into point 1 must be equal to the pipette current, I_p , which flows out of this point. (We can assume that no current flows into the negative input to the amplifier.)

$$I_f = -I_p$$

Substituting into the previous equation:

$$V_o = -I_p R_f + V_p$$

As mentioned above, the feedback resistor forces V_p to be equal to V_{com} so we can substitute V_{com} for V_p to get:

$$V_o = -I_p R_f + V_{com} \text{ or } I_p = (V_{com} - V_o) / R_f$$

Since we know V_{com} and R_f , we can now determine I_p by measuring V_o . Thus the patch clamp amplifier is a current (I_p) -to-voltage (V_o) converter.

C. V_p is, however, connected through the electrode to the cell both of which contain capacitance elements that need to be charged when V_{com} is changed suddenly. To accomplish this, patch clamp amplifiers contain additional compensatory circuits that add waveforms at either input 1 or 2 in order to force V_m to follow more accurately the timecourse of V_{com} .

• The feedback resistor, R_f , is the component in the patch clamp amplifier circuit that makes it

into a current-to-voltage converter. All of the current that flows down the pipette flows through R_f . This resistor determines the gain of the amplifier in V-clamp mode and the amount of current that can be passed in I-clamp mode. In V-clamp, larger values of R_f are selected for single channel recordings where low noise is important and smaller values of R_f are selected in whole-cell recordings where larger currents are necessary.

- As stated above, voltage clamping results from the amplifier operating with negative feedback to “clamp” the pipette voltage, V_p , to the command voltage V_{com} , which you set as part of the experimental protocol. Two important points to consider are:

- The speed at which V_m can respond to a change of V_{com} , which is affected by various capacitances in the electrode and amplifier and
- The fact that V_p is separated from the inside of the cell, V_m , by a significant resistance.

1. Electrode in the bath

- With the electrode in the bath, the pipette resistance, R_p , can be measured by measuring the current flow in response to steps of voltage. To do this command pulses, $V_{seal\ test}$, are applied at V_{com} .

By Ohm’s Law:

$$R_p = V_{seal\ test} / I_p$$

- In this measurement as with all others below, voltages are measured with respect to the bath, which is set to ground potential. Thus with the electrode in the bath, V_p is referenced to ground so current flowing down the pipette flows to ground across R_p . Furthermore, the outside of the cell is also at ground potential, so in whole cell configuration, potentials are measured across the membrane with reference to ground and current flows across the membrane to ground.

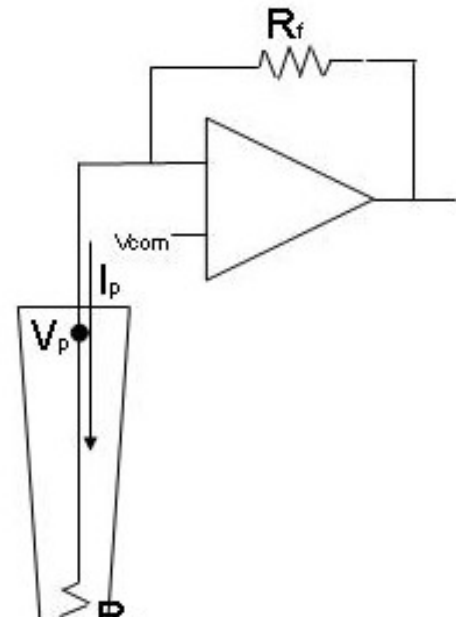

2. Cell attached configuration.

- Once a Giga Ω seal has been formed, current can no longer simply flow through the pipette tip to ground. It must flow through the seal between the pipette tip and the cell membrane. The seal resistance, R_{seal} , can now be calculated by Ohm’s law as was the pipette resistance, although it is necessary to increase the size of the seal test pulse $V_{seal\ test}$ appropriately to calculate the much larger seal resistance:

$$R_{seal} = V_{seal\ test} / I_p$$

- Because the glass tip of the electrode is a thin insulator or dielectric separating two conductors (the bath solution and the pipette filling solution) the pipette tip behaves as a capacitor. The current through a capacitor, $I_c = C\ dV/dt$, is large whenever there is a rapid change in voltage (dV/dt) such as at the beginning and ends of square pulses. In other words, the pipette resistance and capacitance cause the pipette to act on

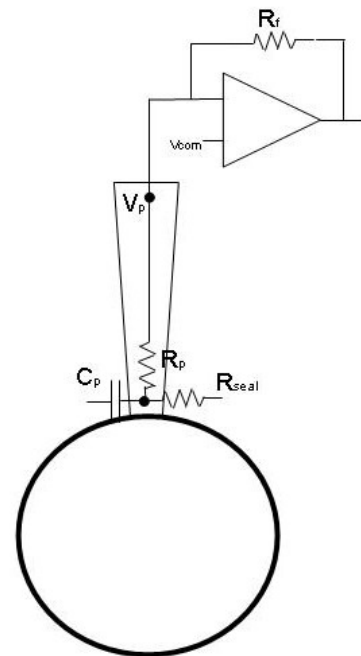

the signal as a low pass filter with a time constant, $\tau_p = R_p C_p$.

- The unwanted filtering produced by the pipette capacitance can be minimized by increasing the pipette tip diameter and thereby decreasing R_p . Since this is not always an option, an alternative is to accomplish this electronically by injecting a current at the input of the patch amplifier (point 1 in the first figure) whose waveform has the effect of negating the effect of C_p . This is called *capacitance compensation* or *capacitance neutralization*. It is important to know that neutralization of C_p is never more than 90% effective so signals are always filtered to some extent by the pipette tip.

3. Whole Cell

- Once the membrane patch has been broken and the whole cell condition is obtained, the membrane resistance, R_m , and membrane capacitance, C_m can be measured since current flowing down the pipette now flows across these components to the grounded bath.
- Voltage pulses applied as V_{com} will produce current transients as I_p whose exponentially decaying waveform is determined approximately by C_m and the input resistance, R_{in} . As with C_p , C_m can be compensated by adding an appropriate waveform to the amplifier input at point 1.

In contrast to C_p , C_m has important biological significance. Since capacitance is defined as $C = \epsilon_0 A / d$ (where ϵ_0 is a property of the lipid in the membrane, and d is the membrane thickness both of which are relatively constant), C_m can be used to determine A , the surface area of the cell.

- After C_m has been effectively compensated, the remaining fairly square step of current is the result of V_{seal} falling ohmically across R_{in} . The biological portion of R_{in} is R_m , which in the resting condition, when ligand-gated and voltage-gated channels are all closed, is a leak resistance produced by ungated “leak” channels. This too can be eliminated by a process known as *leak subtraction*.

4. Series Resistance Compensation.

- Series Resistance is the sum of all of the resistances between the input 1 of the patch clamp amplifier and the cell membrane. It is predominately the sum of R_p , and any access resistance, R_{access} , located between the pipette

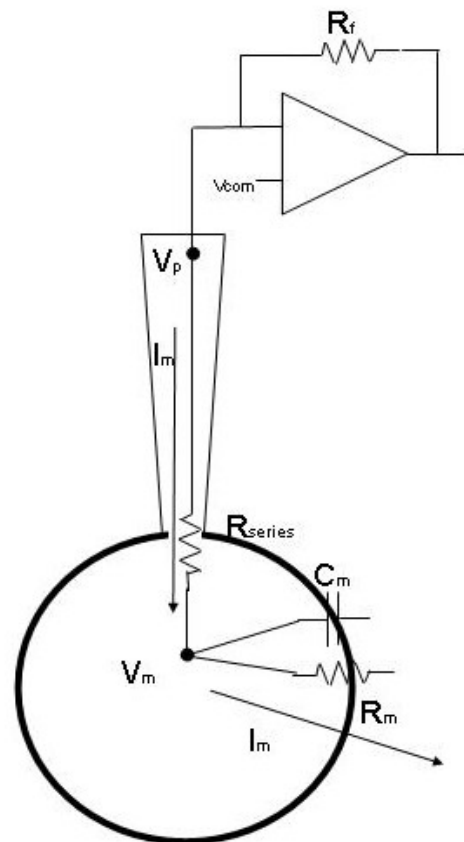
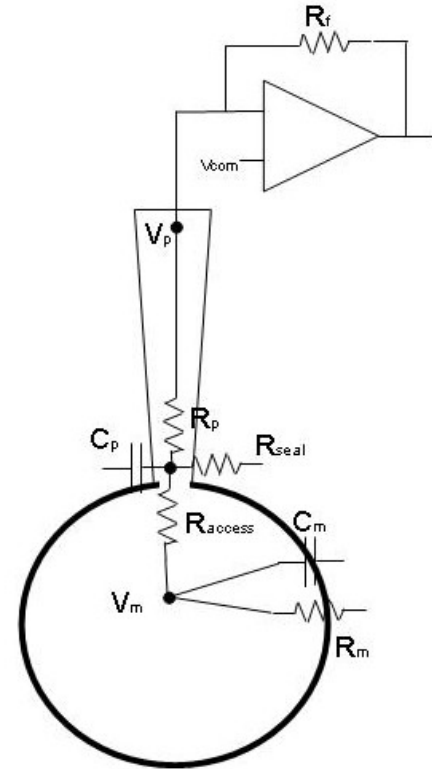

tip and the interior of the cell. Series resistance adds two types of errors in patch clamping:

- 1) Steady state errors. These result because the amplifier clamps V_p , but you are actually interested in clamping V_m . If there is any current flowing through R_{series} , V_p will not be equal to V_m . That is to say:

$$V_m = V_p - I_m R_{series}$$

This difference can be minimized by making R_{series} as small as possible or by keeping I_m small – neither of which is always possible.

- 2) Dynamic errors. Step changes in V_{com} produce changes in V_m with a lag whose time constant is determined by:

$$\tau \approx R_{series} C_m$$

This can put millisecond delays in the rise and fall times of changes of V_m . Thus R_{series} causes I_m to be low pass filtered.

- Series Resistance can be compensated by adding a waveform to input 2 of the patch clamp amplifier that has an effect similar to that in compensating for pipette and membrane capacitance. This has the effect of removing some of the load from R_f when this current pathway is required to supply the current to charge C_m in response to rapid changes in V_{com} .
- Series resistance compensation becomes important either when I_m is large or when rapid changes of V_m are necessary. There are two unfortunate downsides to R_{series} compensation: 1) It adds noise to the I_m signal; 2) Because it is a positive feedback element, it is prone to oscillation. Such oscillation or ringing is especially prevalent when the percent of compensation exceeds about 90%.
- The procedure for R_{series} compensation consists basically of 4 steps:
 - 1) Compensating C_m ,
 - 2) Predicting the amount of R_{series} compensation that will be necessary,
 - 3) Applying this compensation,
 - 4) Making fine adjustments in C_m and C_p compensation.

The overall goal is to speed up the rise time of the change in V_m to more nearly match the rise time of V_{com} . The figures below show the effects of these steps on V_p , V_m , and I_m in response to a step in V_{com} .

- Without any compensation, V_p mimics V_{com} , but V_m rises exponentially with a $\tau \approx R_{series} C_m$ and I_m rises to an initial peak $I_{m(peak)} = V_p / R_{series}$, then falls exponentially with $\tau \approx R_{series} C_m$ to a steady value of $I_{m(ss)} = V_p / R_{series}$.

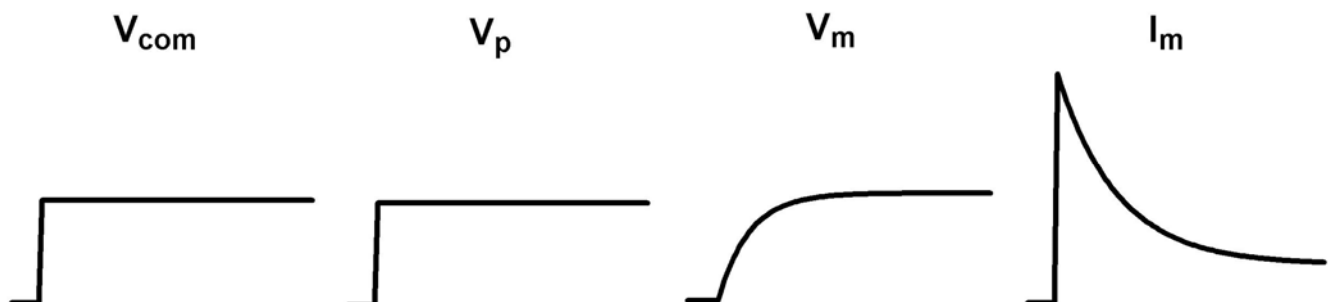

- When C_m is compensated, but R_{series} is still uncompensated, V_p still mimics V_{com} and V_m still rises exponentially with a $\tau \approx R_{series}C_m$, however, I_m now has no initial transient, but rises slowly to the same steady value of $I_{m(ss)} = V_p/R_m$.

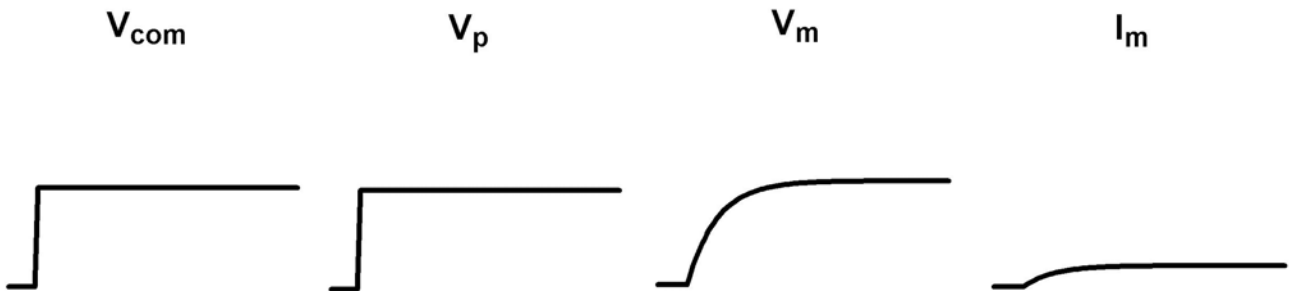

- When C_m and R_{series} are both compensated, V_p no longer mimics V_{com} because the R_{series} compensation is now being added at input 2 to the patch clamp amplifier. There is still some lag, but now V_m rises much faster than the previous $\tau \approx R_{series}C_m$. I_m also rises much faster and suffers from some added noise. Appropriate compensation is a trade off between too slow a rise in I_m and overshoot and oscillations in the rise of I_m .

